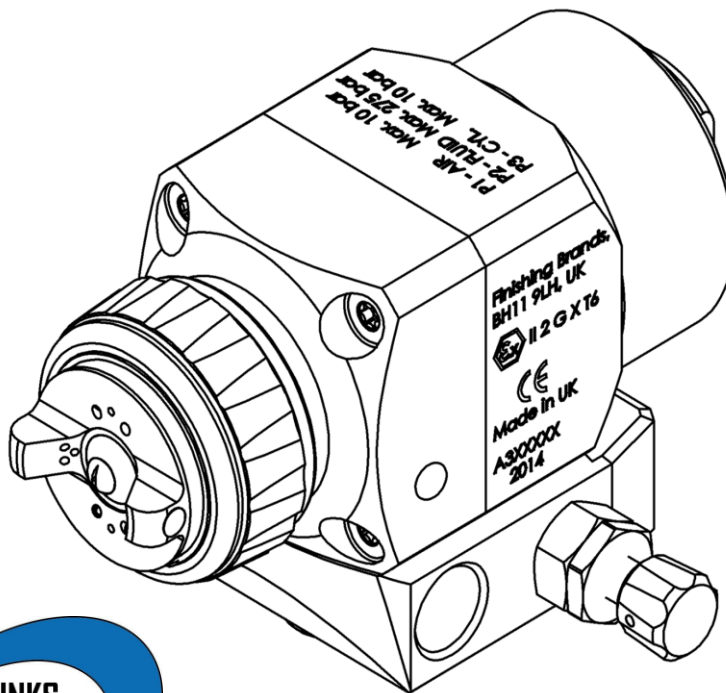

BINKS®**BINKS AG360 Series:**

AG363 Air Assisted Airless Automatic Manifold Gun.

CE  II 2 G X T6

IMPORTANT! DO NOT DESTROY

It is the Customer's responsibility to have all operators and service personnel read and understand this manual.

Contact your local Binks representative for additional copies of this manual.

READ ALL INSTRUCTIONS BEFORE OPERATING THIS BINKS PRODUCT.

FUNCTIONAL DESCRIPTION

The AG363 Air Assisted Airless gun is designed to be fast change-over, modular construction applicator for spray finishing on machines and fixed mountings.

Intended for most types of general industrial coatings and fine finishing operations, the gun features a stainless steel head suitable for both water based and solvent based applications.

The AG363 is mounted on a screw attached low profile stainless steel manifold which can remain in position on the machine while the gun is removed for maintenance or cleaning operations.

The gun is designed as a flexible solution for the modern coating applicator with multiple accessories available to further optimise the process.

SPECIFICATIONS

FLUID AND AIR INLET PRESSURES	
P1 = Max Air Input Pressure	10 Bar [145 psi]
P2 = Max Fluid Input Pressure	275 Bar [4000 psi]
P3 = Cylinder Air Pressure	4 - 10 Bar [58 psi - 145 psi]

ENVIRONMENTAL	
Max Ambient Operating Temperature	40°C Nominal [104°F]

MATERIALS OF CONSTRUCTION	
Gun Head and Fluid Passageways	Stainless Steel
Gun Body Material	Quickclean™ Coated Aluminium
Air Cap Material	Anodised Aluminium
Fluid Needle and Seat Construction	Stainless Steel Tungsten Carbide
Seals and O-Rings	HDPE, FEPM

SCREW TYPE MANIFOLD CONNECTIONS	
P1 = Air Inlet Size	1/4" G
P2 = Fluid Inlet Size	1/4" NPS
P3 = Cylinder Inlet	1/8" G

WEIGHT WITH MANIFOLD	
WEIGHT	840g

DIMENSIONS WITH MANIFOLD	
L x H x W mm	110 x 64 x 89

Product Description:	AG363
This Product is designed for use with:	Solvent and water based materials
Suitable for use in hazardous area:	Zone 1 & 2
Protection Level:	II 2 G X T6
Vibration Level:	N/A
Sound Pressure Level:	Available on request
Sound Power Level:	Available on request
Manufacturer:	Finishing Brands UK, Ringwood Road, Bournemouth, BH11 9LH. UK

EU Declaration of Conformity



We: Finishing Brands UK, declare that the above product conforms with the Provisions of:

Machinery Directive 2006/42/EC

ATEX Directive 94/9/EC

by complying with the following statutory documents and harmonised standards:

BS EN 1953:2013 Atomising and spraying equipment for coating materials - Safety requirements

EN ISO 12100-1:2010 Safety of Machinery - Basic concepts, general principles for design - Basic terminology, methodology

EN ISO 12100-2:2010 Safety of Machinery - Basic concepts, general principles for design - Technical principles

EN 14462:2005+A1:2009 Surface treatment equipment - Noise test code for surface treatment equipment including its ancillary handling equipment - Accuracy grades 2 and 3

EN ISO 11201:1995 Acoustics - Noise by machinery and equipment - Determination of emission sound pressure levels at a work station and at other specified positions in an essentially free field over a reflecting plane with negligible environmental corrections

EN1127-1: Explosive atmospheres - Explosion prevention - Basic concepts

EN 13463-1: Non electrical equipment for use in potentially explosive atmospheres - Basic methods and requirements

HVLP and Trans-Tech products comply with the requirements of PG6 from the EPA guidelines and offer greater than 65% transfer efficiency.

D Smith (General Manager)
30/01/15

! WARNING	! CAUTION	NOTE
Hazards or unsafe practices which could result in severe personal injury, death or substantial property damage.	Hazards or unsafe practices which could result in minor personal injury, product or property damage.	Important installation, operation or maintenance information.



WARNING

Read the following warnings before using this equipment.



SOLVENTS AND COATING MATERIALS. Can be highly flammable or combustible when sprayed. Always refer to the coating material supplier's instructions and safety sheets before using this equipment.



INSPECT THE EQUIPMENT DAILY. Inspect the equipment for worn or broken parts on a daily basis. Do not operate the equipment if you are uncertain about its condition.



READ THE MANUAL. Before operating finishing equipment, read and understand all safety, operation and maintenance information provided in the operation manual. Users must comply with all local and national codes of practice and insurance company requirements governing ventilation, fire precautions, operation and house-keeping of working areas.



EQUIPMENT MISUSE HAZARD. Equipment misuse can cause the equipment to rupture, malfunction or start unexpectedly and result in serious injury.



FIRE AND EXPLOSION HAZARD. Never use 1,1,1-Trichloroethane, Methylene Chloride, other Halogenated Hydrocarbon solvents or fluids containing such solvents in equipment with aluminium wetted parts. Such use could result in a serious chemical reaction, with the possibility of explosion. Consult your fluid suppliers to ensure that the fluids being used are compatible with aluminium parts.



GLOVES. Must be worn when spraying or cleaning the equipment.



WEAR SAFETY GLASSES. Failure to wear safety glasses with side shields could result in serious eye injury or blindness.



STATIC CHARGE. Fluid may develop a static charge that must be dissipated through proper grounding of the equipment, objects to be sprayed and all other electrically conductive objects in the dispensing area. Improper grounding or sparks can cause a hazardous condition and result in fire, explosion or electric shock and other serious injury.



WEAR RESPIRATOR. The use of respiratory protective equipment is recommended at all times. The type of equipment must be compatible with the material being sprayed.



TOXIC VAPOURS. When sprayed, certain materials may be poisonous, create irritation, or are otherwise harmful to health. Always read all labels, safety sheets and follow any recommendations for the material before spraying. If in doubt contact your material supplier.



NEVER MODIFY THE EQUIPMENT. Do not modify the equipment unless the manufacturer provides written approval.



LOCK OUT / TAG-OUT. Failure to de-energise, disconnect, lock out and tag-out all power sources before performing equipment maintenance could cause serious injury or death.

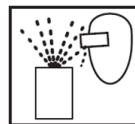

PROJECTILE HAZARD. You may be injured by venting liquids or gases that are released under pressure, or flying debris.



NOISE LEVELS. The A-weighted sound level of pumping and spray equipment may exceed 85 dB(A) depending on equipment settings. Actual noise levels are available on request. It is recommended that ear protection is worn at all times while equipment is in use.



PRESSURE RELIEF PROCEDURE. Always follow the pressure relief procedure in the equipment instruction manual.



KNOW WHERE AND HOW TO SHUT OFF THE EQUIPMENT IN CASE OF AN EMERGENCY.



HIGH PRESSURE CONSIDERATION. High pressure can cause serious injury. Relieve all pressure before servicing. Spray from the gun, hose leaks or ruptured components can inject fluid into your body and cause extremely serious injury.



OPERATOR TRAINING. All personnel must be trained before operating finishing equipment.

IT IS THE RESPONSIBILITY OF THE EMPLOYER TO PROVIDE THIS INFORMATION TO THE OPERATOR OF THE EQUIPMENT.

AG363 GUN PART NUMBER FORMAT & PART SELECTION GUIDE

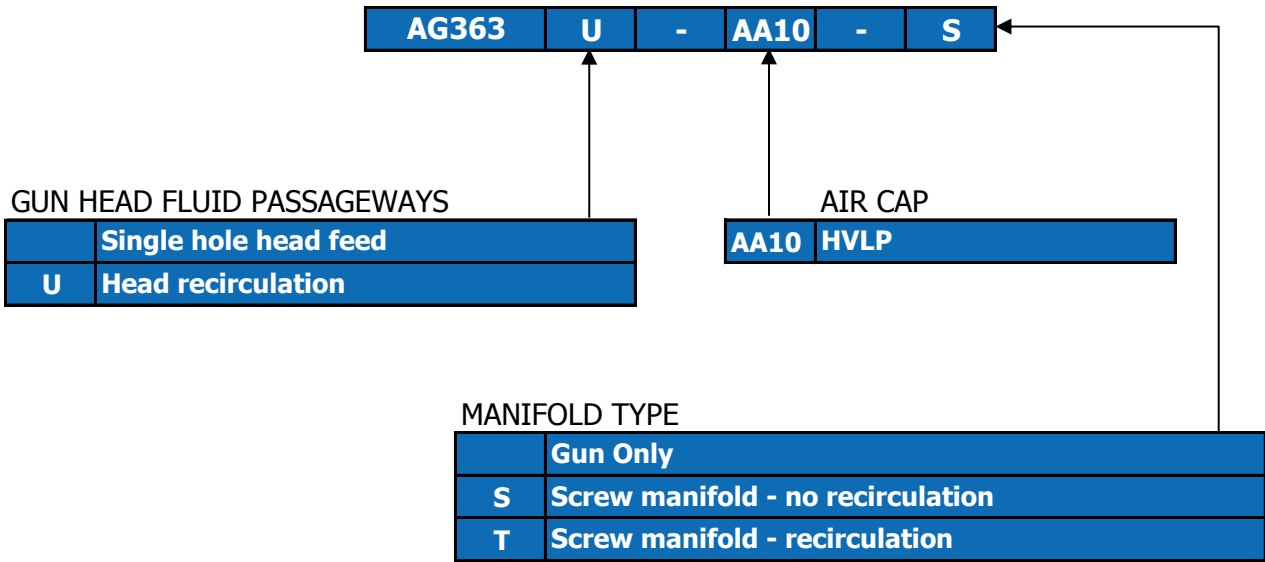

AIR ASSISTED AIRLESS (AAA) TIP SELECTION CHART

(ORDERED SEPARATELY)

114 STANDARD TIPS						
PART No.	ORIFICE		FAN LENGTH*		FLOW [WATER @ 500 psi/35 Bar]	
	INCH	MM	INCH	MM	US GPM	L/MIN
114-00702	-	-	-	-	-	-
114-00704	0.007	0.18	4	102	0.028	0.11
114-00706	0.007	0.18	6	152	0.028	0.11
114-00708	0.007	0.18	8	203	0.028	0.11
114-00902	0.009	0.23	2	51	0.039	0.15
114-00904	-	-	-	-	-	-
114-00906	0.009	0.23	6	152	0.039	0.15
114-00908	0.009	0.23	8	203	0.039	0.15
114-00910	0.009	0.23	10	254	0.039	0.15
114-00912	0.009	0.23	12	305	0.039	0.15
114-01104	0.011	0.28	4	102	0.06	0.23
114-01106	0.011	0.28	6	152	0.06	0.23
114-01108	0.011	0.28	8	203	0.06	0.23
114-01110	0.011	0.28	10	254	0.06	0.23
114-01112	0.011	0.28	12	305	0.06	0.23
114-01114	0.011	0.28	14	356	0.06	0.23
114-01304	0.013	0.33	4	102	0.09	0.34
114-01306	0.013	0.33	6	152	0.09	0.34
114-01308	0.013	0.33	8	203	0.09	0.34
114-01310	0.013	0.33	10	254	0.09	0.34
114-01312	0.013	0.33	12	305	0.09	0.34
114-01314	0.013	0.33	14	356	0.09	0.34
114-01316	0.013	0.33	16	406	0.09	0.34
114-01506	0.015	0.38	6	152	0.12	0.45
114-01508	0.015	0.38	8	203	0.12	0.45
114-01510	0.015	0.38	10	254	0.12	0.45
114-01512	0.015	0.38	12	305	0.12	0.45
114-01514	0.015	0.38	14	356	0.12	0.45
114-01516	0.015	0.38	16	406	0.12	0.45
114-01518	0.015	0.38	18	457	0.12	0.45
114-01706	0.017	0.43	6	152	0.16	0.61
114-01708	0.017	0.43	8	203	0.16	0.61
114-01710	0.017	0.43	10	254	0.16	0.61
114-01712	0.017	0.43	12	305	0.16	0.61
114-01714	0.017	0.43	14	356	0.16	0.61
114-01716	0.017	0.43	16	406	0.16	0.61
114-01718	0.017	0.43	18	457	0.16	0.61
114-01906	0.019	0.48	6	152	0.19	0.72
114-01908	0.019	0.48	8	203	0.19	0.72
114-01910	0.019	0.48	10	254	0.19	0.72
114-01912	0.019	0.48	12	305	0.19	0.72
114-01914	0.019	0.48	14	356	0.19	0.72
114-01916	0.019	0.48	16	406	0.19	0.72
114-01918	0.019	0.48	18	457	0.19	0.72
114-02110	0.021	0.53	10	254	0.24	0.91
114-02112	0.021	0.53	12	305	0.24	0.91
114-02114	0.021	0.53	14	356	0.24	0.91
114-02116	0.021	0.53	16	406	0.24	0.91
114-02118	0.021	0.53	18	457	0.24	0.91
114-02410	0.024	0.61	10	254	0.31	1.17
114-02412	0.024	0.61	12	305	0.31	1.17
114-02414	0.024	0.61	14	356	0.31	1.17
114-02416	0.024	0.61	16	406	0.31	1.17
114-02418	0.024	0.61	18	457	0.31	1.17
114-02710	0.027	0.69	10	254	0.385	1.46
114-02712	0.027	0.69	12	305	0.385	1.46
114-02714	0.027	0.69	14	356	0.385	1.46
114-02716	0.027	0.69	16	406	0.385	1.46
114-02718	0.027	0.69	18	457	0.385	1.46

* FAN LENGTH BASED ON 1000 psi/70 Bar WATER, ACTUAL RESULTS MAY VARY, DEPENDING ON MATERIAL VISCOSITY

IN ADDITION TO THE 114 SERIES STANDARD TIP RANGE THERE IS THE 9-SERIES FINE FINISH RANGE.

TYPICAL AIR CONNECTION SCHEMATIC

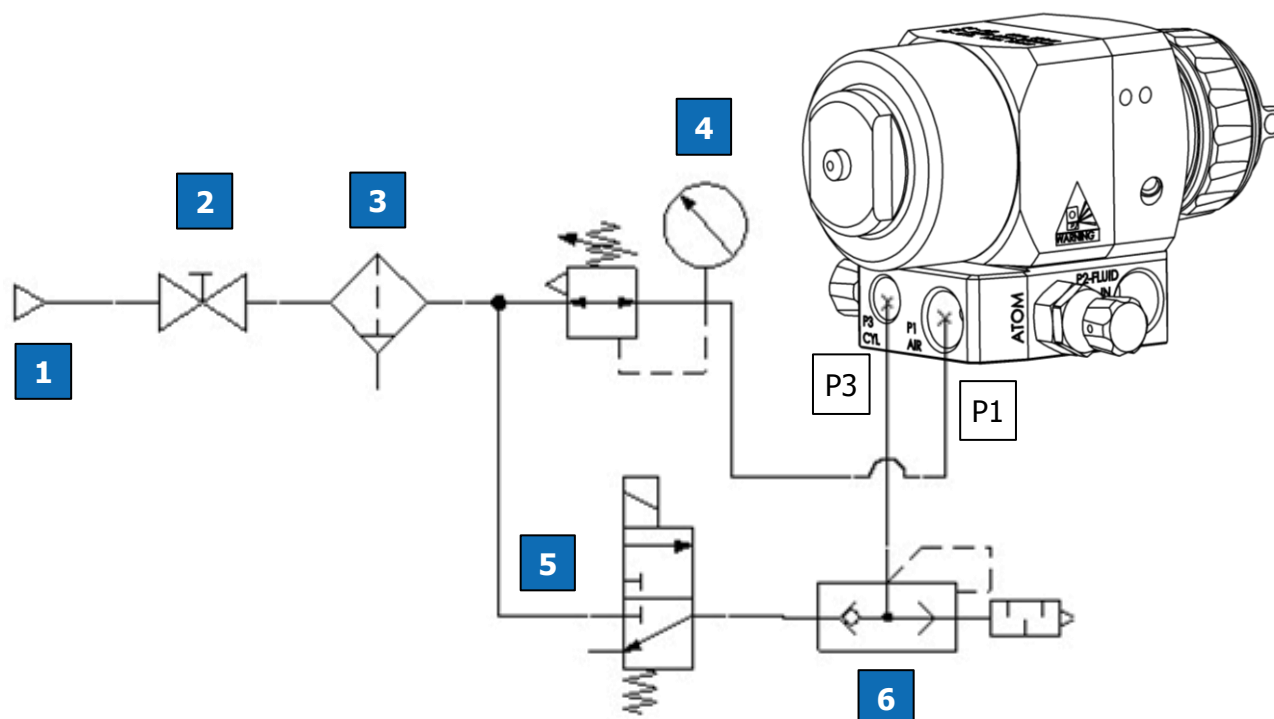

1	Compressed air take-off
2	Shut-off valve
3	Air filter
4	Air regulator & gauge
5	3/2 solenoid valve, normally closed
6	Quick exhaust valve & silencer
P1	CAP - 1/4" G
P3	CYL - 1/8" G

**WARNING**

The spray gun must be earthed to dissipate any electrostatic charges which may be created by fluid or air flows. This can be achieved through the spray gun mounting, or conductive air/fluid hoses. Electrical bond from the spray gun to earth should be checked and a resistance of less than 10^6 Ohms is required.

TYPICAL FLUID CONNECTION SCHEMATIC

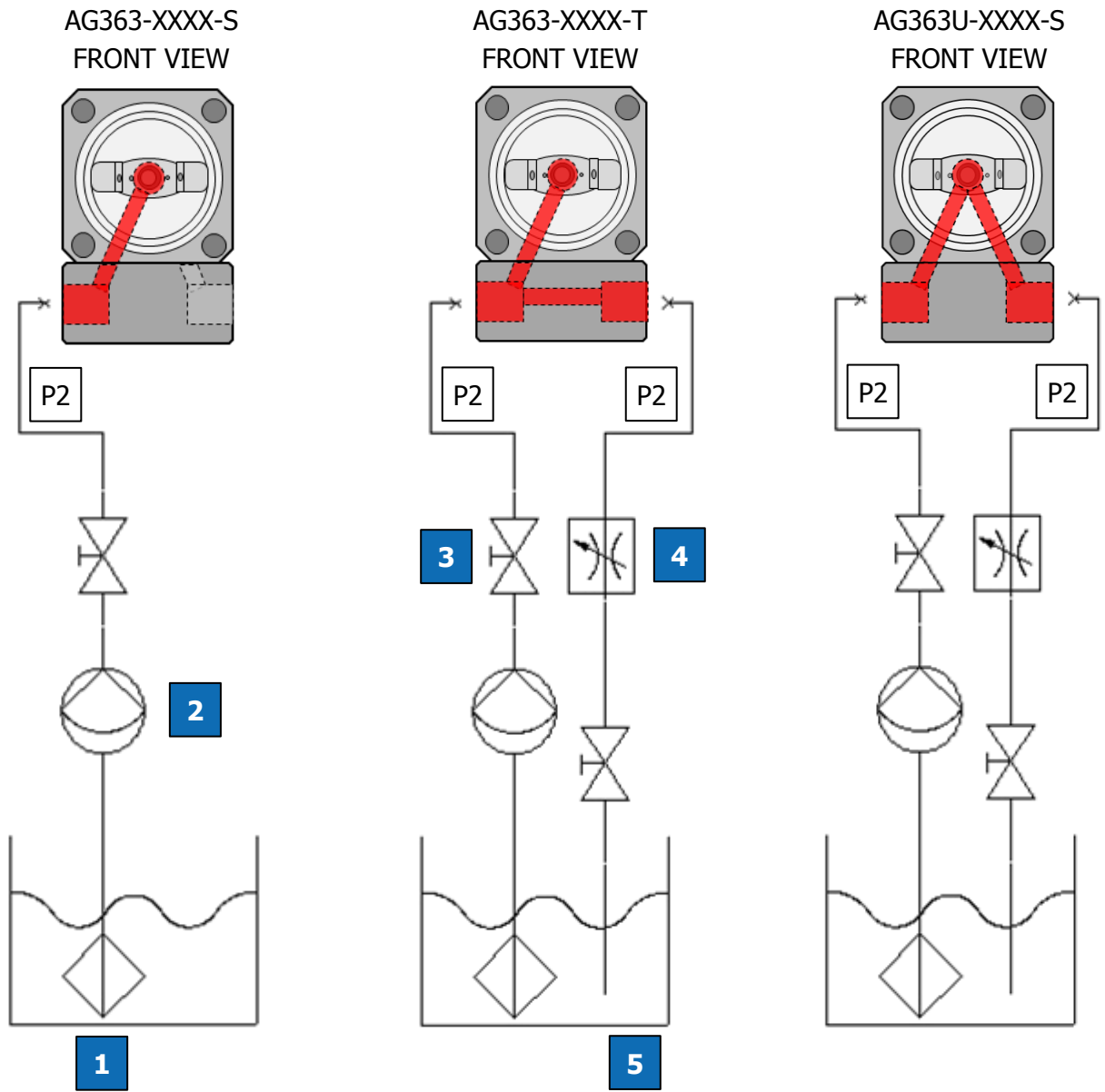

1	Fluid filter
2	Fluid supply
3	Shut-off valve
4	Fluid restrictor valve
5	Fluid reservoir
P2	Fluid - 1/4" NPS

NOTE

Protective coatings have been used for storage protection. Flush the equipment fluid passageways with appropriate solvent before use.

SPRAY GUN AND MANIFOLD INSTALLATION

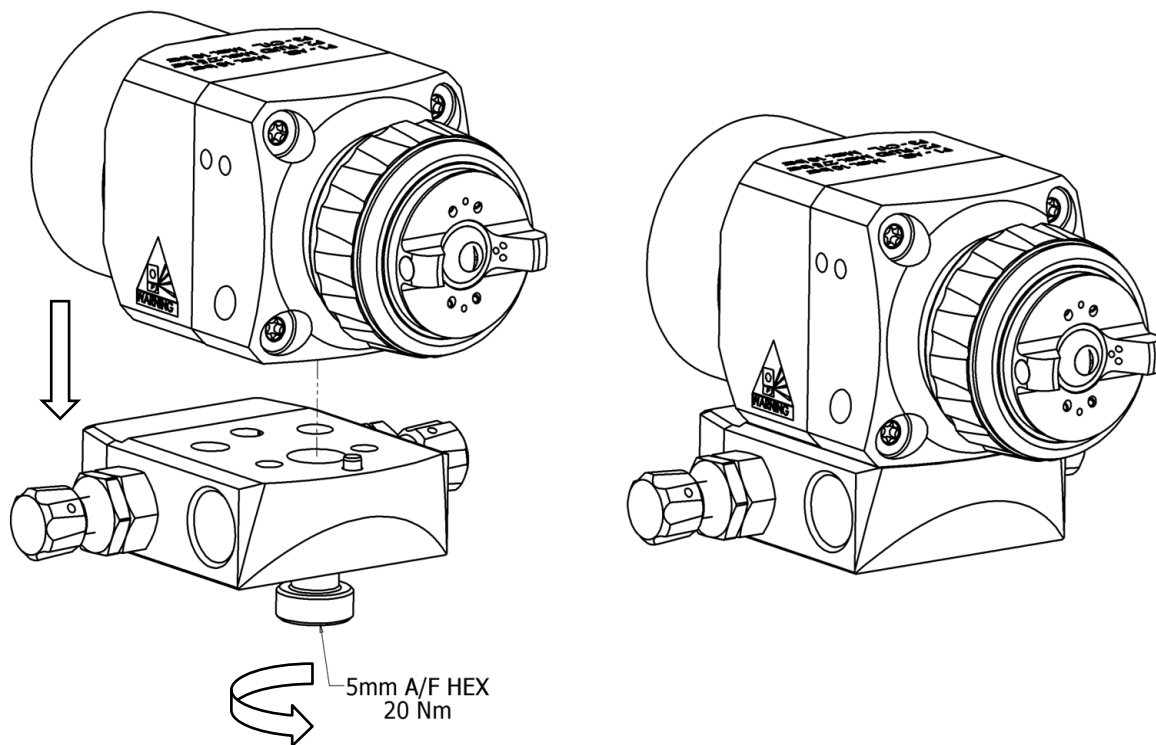

EXPLODED VIEW

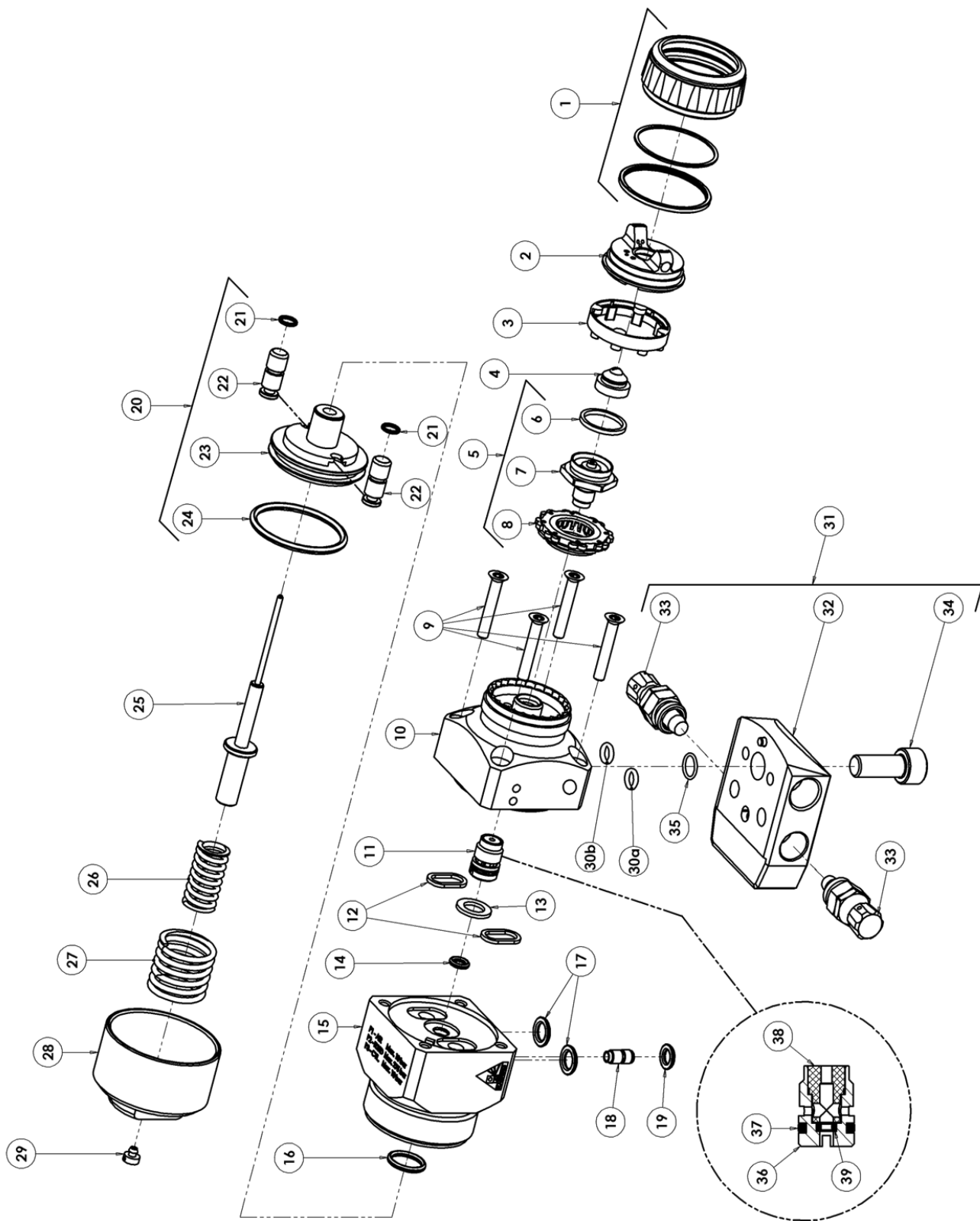

PARTS LIST

REF.	PART No.	DESCRIPTION	ASSEMBLY QTY.
1	ADV-403-K	RETAINING RING WITH SEALS	1
2	54-5890	AA10 AIR CAP	1
3	SPA-70-K10	INDEX PLATE (KIT OF 10)	1
4	SEE TABLE	FLUID TIP	1
5	SPA-69-K	NEEDLE SEAT ASSY	1
6	SPA-98-K10	GASKET (KIT OF 10)	1
7	-	NEEDLE SEAT	1
8	SPA-71-K10	BAFFLE PLATE (KIT OF 10)	1
9	S-14190-K4	TORX SCREW (KIT OF 4)	4
10	SPA-156-K	SPRAYHEAD	1
	SPA-156U-K	SPRAYHEAD RECIRCULATION	1
11	SPA-76	NEEDLE PACKING	1
12	SPA-53-K10	GASKET (KIT OF 10)	2
13	SPA-97-K10	GASKET (KIT OF 10)	1
14	S-28219X-K4	O RING (KIT OF 4)	1
15	SPA-65-BL-K	BODY	1
16	S-28220X-K2	O RING (KIT OF 2)	1
17	SPA-29X-K4	O RING (KIT OF 4)	2
18	SPA-52	AIR TUBE	1
19	S-28223X-K4	O RING (KIT OF 4)	1
20	SPA-68-K	PISTON	1
21	S-28224X-K4	O RING (KIT OF 4)	2
22	SPA-62-K2	AIR VALVE PISTON (KIT OF 2)	2
23	-	PISTON	1
24	SPA-45X-K2	O RING (KIT OF 2)	1
25	SPA-79	FLUID NEEDLE	1
26	SPA-77	NEEDLE SPRING	1
27	SPA-13	PISTON SPRING	1
28	SPA-67-BL-K	END CAP	1
29	SPA-54	VENT CAP	1
30a	SN-71X-K2	O RING	1
30b		O-RING (HEAD RECIRCULATION ONLY)	2
31	SPA-419-K	SCREW MANIFOLD ASSEMBLY	1
	SPA-419P-K	SCREW MANIFOLD ASSEMBLY PLUGGED	1
	SPA-419U-K	RECIRCULATION SCREW MANIFOLD ASSEMBLY	1
	SPA-419UP-K	RECIRCULATION SCREW MANIFOLD ASSEMBLY PLUGGED	1
32	-	MANIFOLD	1
33	SPA-414-K	CONTROL VALVE	2
34	SPA-161-K2	CLAMPING SCREW (KIT OF 2)	1
35	-	O-RING (PART OF SPA-161-K2)	1
36	-	HOUSING	1

PARTS LIST (Continued)

REF.	PART No.	DESCRIPTION	ASSEMBLY QTY.
37	SPA-29X-K4	O RING (KIT OF 4)	1
38	SPA-96-K4	SEAL	1
39	SPA-46X-K4	O RING (KIT OF 2)	1

TYPICAL SETTING

1. The ATOM air valve controls the length of the fan pattern, the FAN valve controls the shape of the pattern. To increase the air pressure, turn air control valves anti-clockwise and to reduce the pressure turn clockwise.
2. Fluid flow can be adjusted through pump pressure, air pressure or tip size.



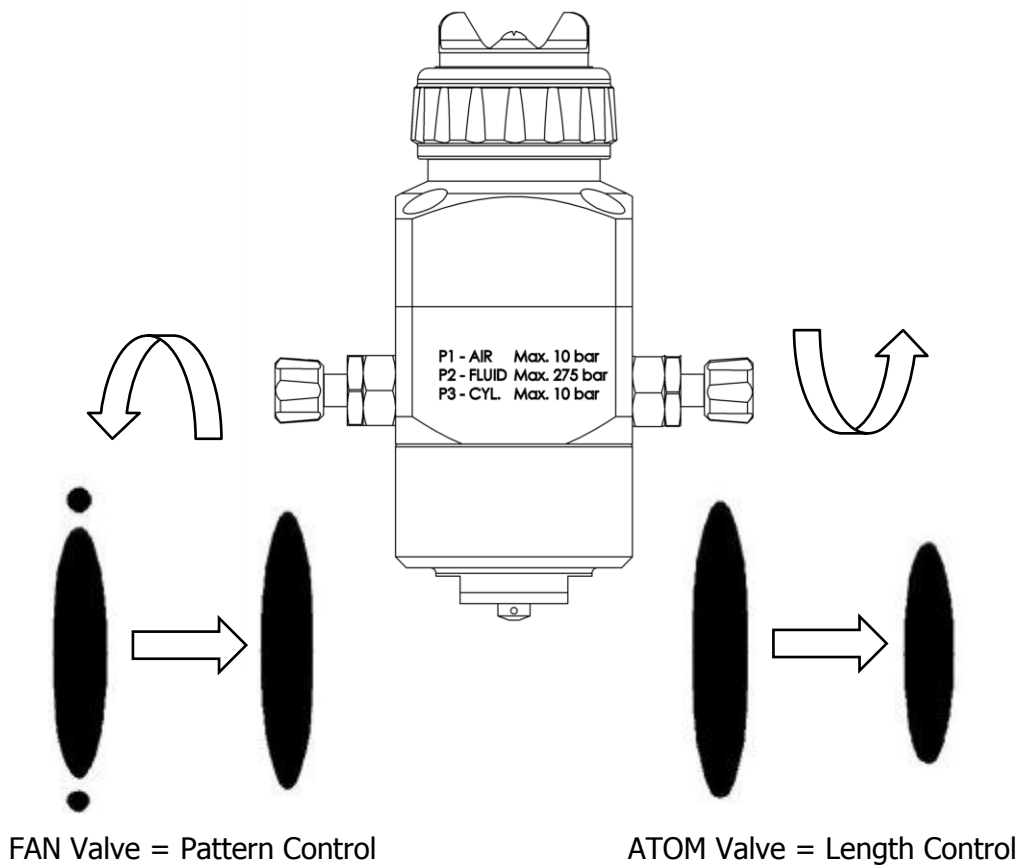

TYPICAL START-UP SEQUENCE

Screw FAN and ATOM control knobs fully closed.

1. Select AAA tip size and angle to give pattern size, flow rate and atomisation. Adjust fluid pressure as required.
2. Turn FAN control knob out anticlockwise until tails are removed from pattern.
3. Turn ATOM control knob as shown, for small adjustments to pattern length. (Under normal circumstances we recommend you change the tip for one with an alternate angle.)



SPRAY GUN MAINTENANCE

KEY - MAINTENANCE SYMBOLS	
	Order for disassembly <i>(reverse for assembly)</i>
#	Item Number
	Petroleum Grease/Jelly
	Thread Sealant
	Thread Locker

DISASSEMBLY TIP & NEEDLE

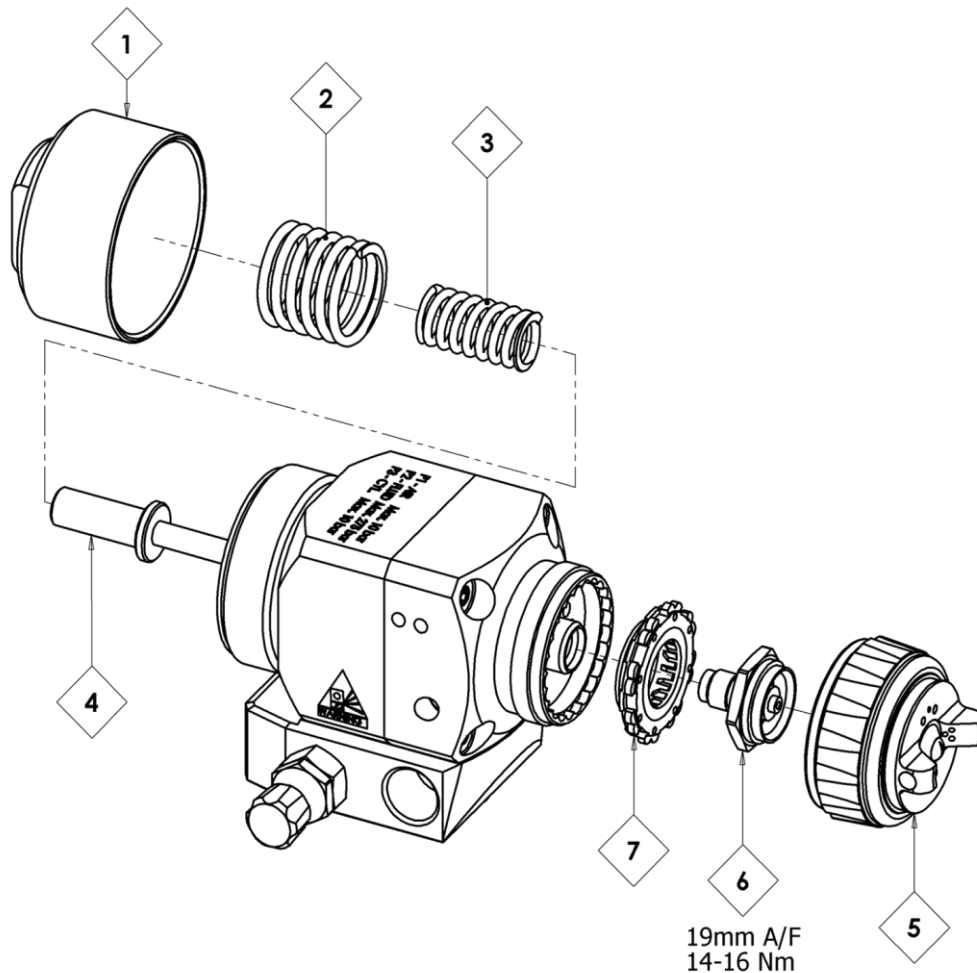

DISASSEMBLY AIR CAP, TIP & INDEXING

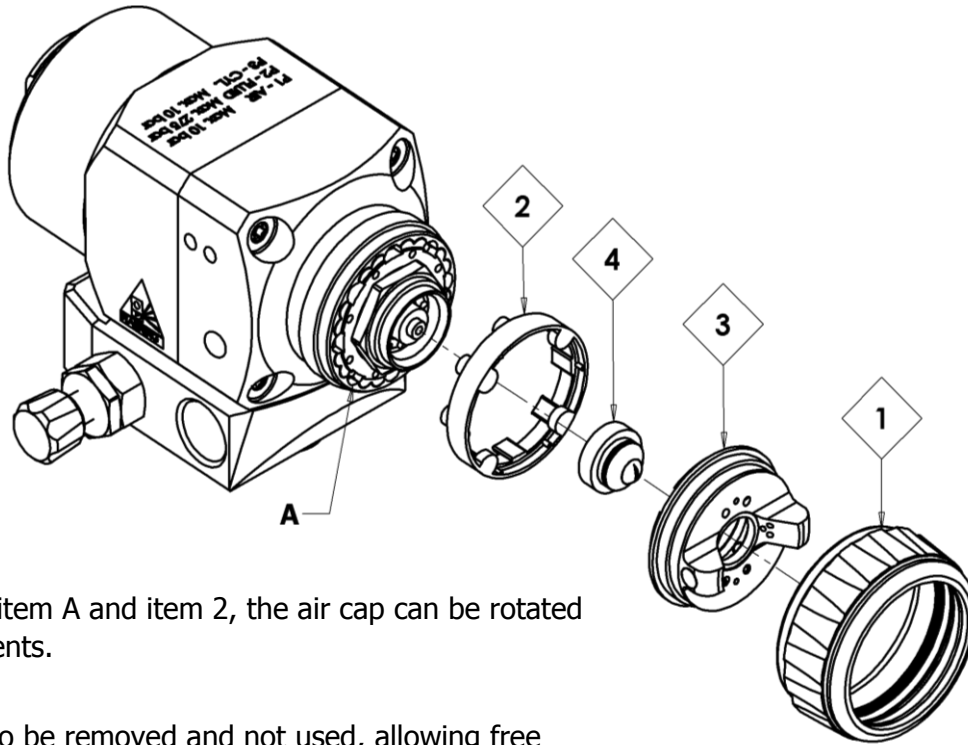

By combining item A and item 2, the air cap can be rotated at 15° increments.

Item 2 can also be removed and not used, allowing free rotation.

DISASSEMBLY PISTON

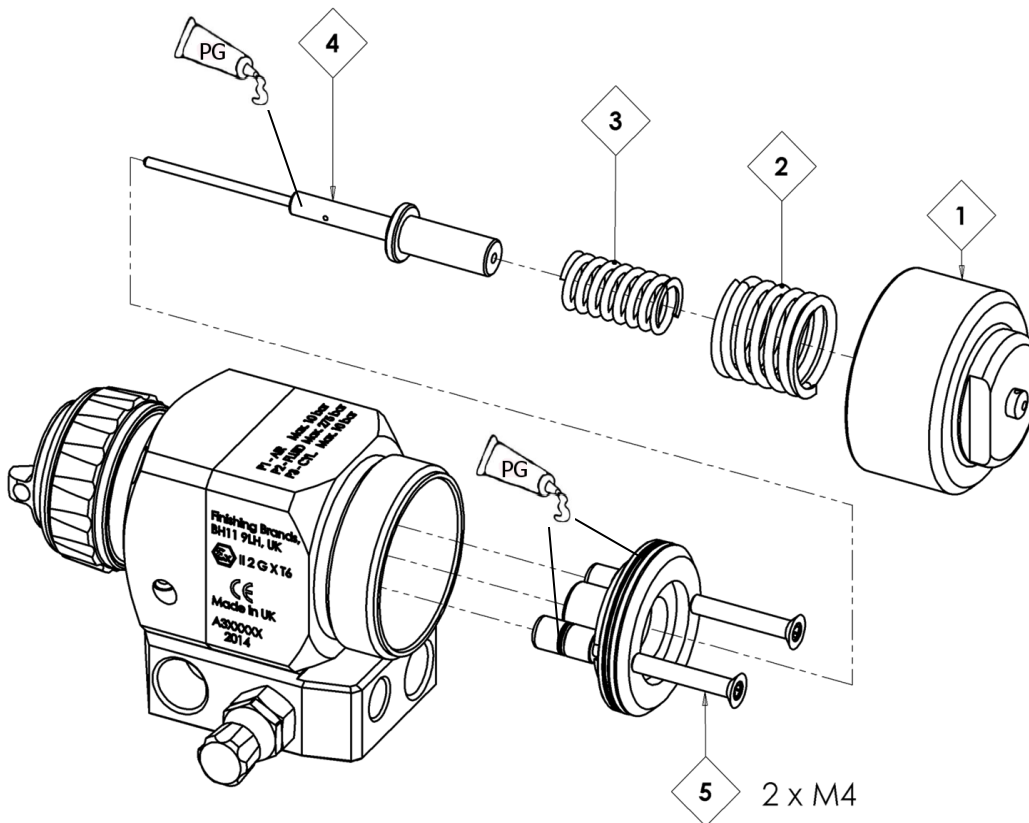

2 x M4

Install screws to remove piston.

DISASSEMBLY PACKING

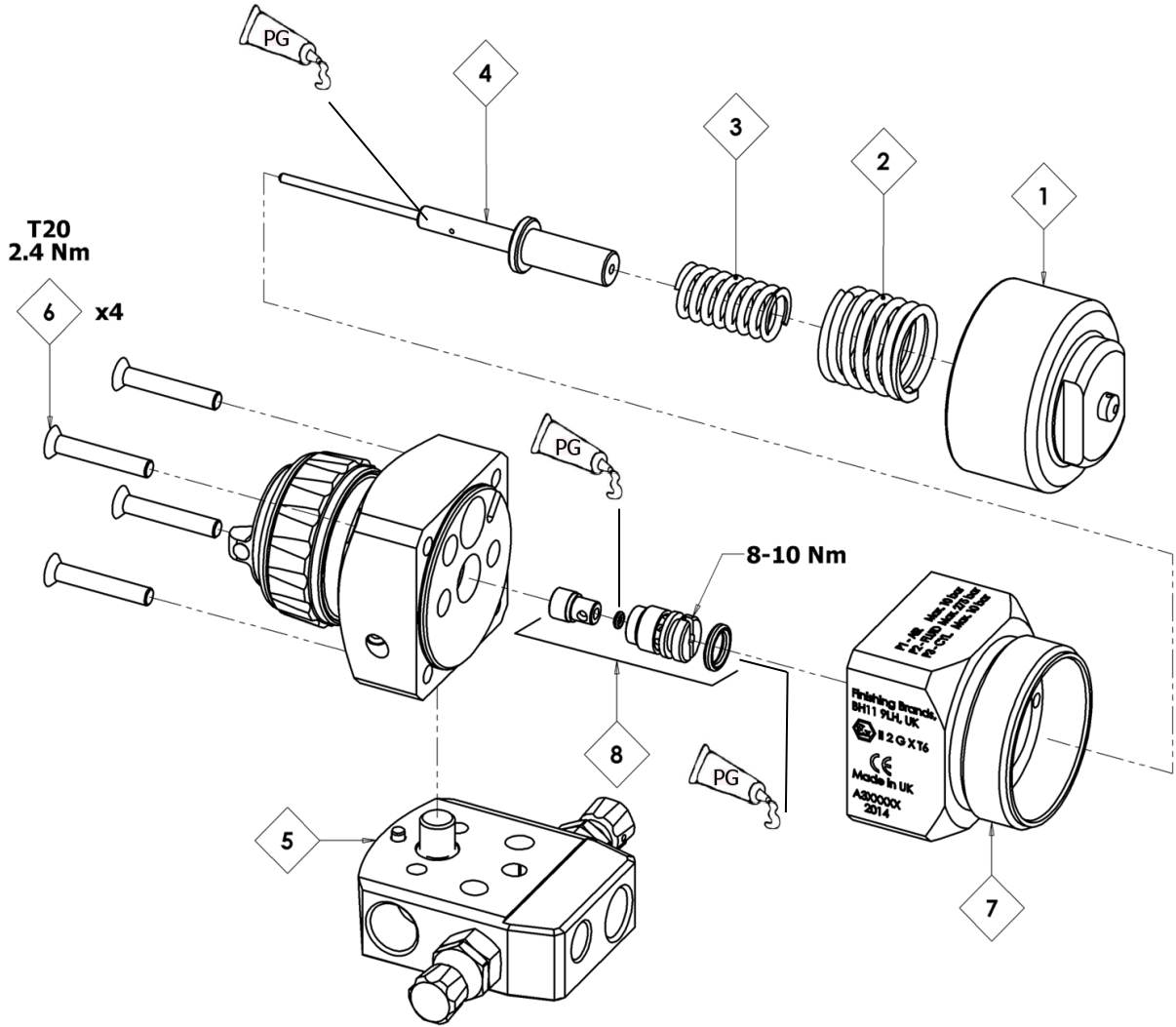

TROUBLESHOOTING MECHANICAL PERFORMANCE

GENERAL FAULTS	CAUSE	CORRECTION
Will not spray.	No cylinder air pressure at gun.	Check air supply and air line.
	Blocked tip.	Replace or clean.
Gun spits paint when triggering on due to paint build-up inside air cap between spraying operations.	Needle seat not fitted correctly in gun head.	Tighten.
	Fluid tip/needle leakage.	Check for damage or blockage.
Paint build-up on fluid tip.	Coating type promotes build-up.	Consult coating supplier.
	Damaged or partially blocked tip.	Check for damage or blockage.
Paint build-up on air cap.	Damaged air cap holes.	Replace with new air cap.
	Gradual build-up of bounce-back on gun head.	Thoroughly clean.
Air cap fills with paint when triggered.	Tip not seated correctly.	Replace with new fluid tip.
	Tip seat worn in rear of tip.	
	Fluid tip not tight.	Tighten.

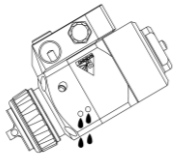
FLUID FAULTS	CAUSE	CORRECTION
Slow fluid leak from needle seat.	Needle seat internal surface scored damaged or worn.	Replace.
	Fluid needle external profile damaged or worn.	Replace.
	Contamination on needle or seat mating surfaces preventing good seal.	Thoroughly clean.
Major fluid leak or fluid jetting from fluid tip or needle seat, when gun is off.	Contamination on needle or seat mating surfaces preventing good seal.	Remove tip and needle and thoroughly clean.
Slow fluid leak from needle packing, three possible places. 	Fluid needle packing worn or loose.	Tighten or replace as necessary.
Gun will not shut off.	Fluid pressure above gun max working pressure.	Reduce fluid pressure.

AIR FAULTS	CAUSE	CORRECTION
Small air leak from air cap when gun is not triggered.	Piston contaminated and not correctly seating.	Remove piston and thoroughly clean valve shaft and seating surfaces.
	Piston seal damaged or missing.	Replace.

SCREW TYPE MANIFOLD FAULTS

ASSEMBLY FAULTS	CAUSE	CORRECTION
Spray gun is loose when assembled onto manifold.	Clamping screw has not been tightened.	Tighten screw.
	Clamping screw has worn.	Replace using clamping screw kit SPA-161-K2.
Spray gun cannot be removed from manifold.	Clamping screw still in place.	Remove clamping screw.

TROUBLESHOOTING SPRAY PERFORMANCE

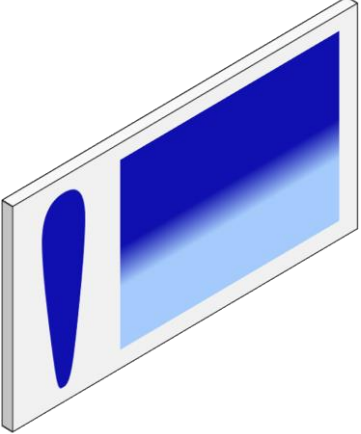
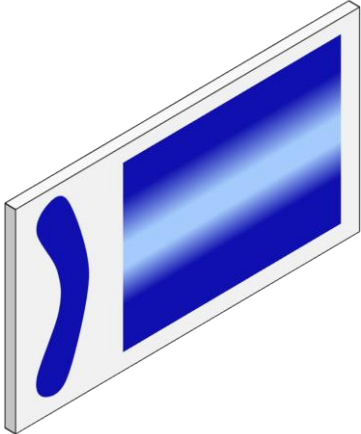
CONDITION	CAUSE	CORRECTION
Heavy top or bottom pattern. 	Material build-up on air cap, plugged holes, or jets.	Soak cap or tip in suitable solvent and thoroughly clean.
	Material build-up on fluid tip exterior or partially plugged fluid tip.	Replace fluid tip or air cap if necessary.
		Thoroughly clean.
Heavy right or left side pattern. 	Left or right side air holes plugged.	Soak cap or tip in suitable solvent and thoroughly clean.
	Dirt or damage on left or right side of fluid tip exterior.	Replace fluid tip if necessary.

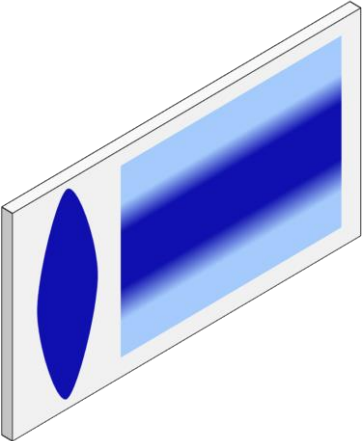
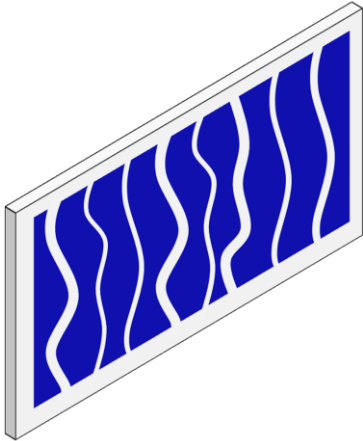
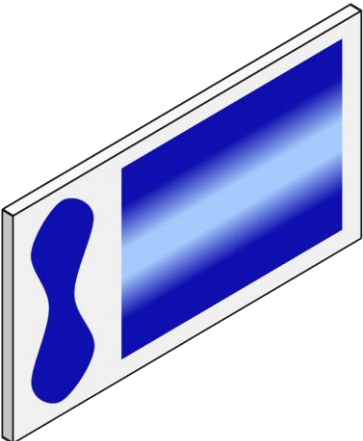
<p>Heavy centre pattern.</p> 	<p>Too much material.</p>	<p>Change tip.</p>
<p>Intermittent or 'fluttering' spray fan.</p> 	<p>Air in paint supply line.</p>	<p>Check and tighten pump siphon hose connections.</p>
<p>Split spray pattern</p> 	<p>Partially obstructed fluid passage or hose.</p>	<p>Bleed air from supply line.</p>
	<p>Damaged or dirty fluid tip</p>	<p>Clean or replace.</p>
	<p>Too high atom (length control) pressure.</p>	<p>Reduce air pressure by rotating pattern control valve clockwise.</p>

Excessive bounce-back.	Too much air pressure.	Reduce air pressure.
Runs and sags.	Too much fluid flow.	Reduce tip size or reduce fluid pressure.
	Material too thin.	Apply light coats/reduce fluid flow.
	Gun tilted at an angle.	Mount gun at right angle to work.
Thin, sandy coarse finish drying before it flows out.	Gun too far from surface.	Check distance.
	Too much air pressure.	Reduce air pressure and check spray pattern.
	Fluid flow too low.	Increase fluid flow by increasing fluid tip size or supply pressure.

MOUNTING ADAPTOR OPTIONS - SCREW TYPE MANIFOLD

SPA-173-K

Horizontal mounting bar and screws

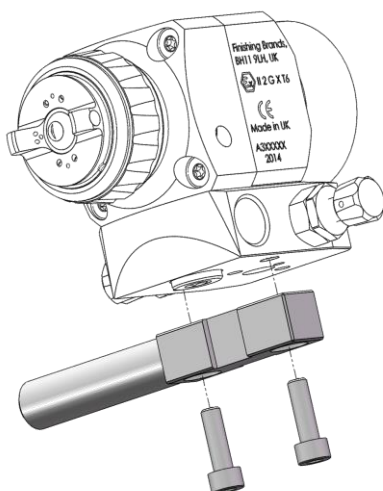

SPA-174-K

Vertical mounting bar and screws

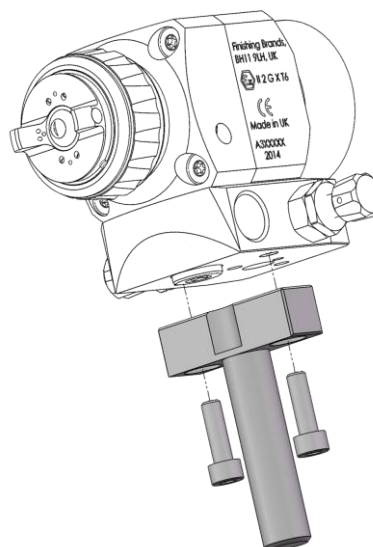

SPA-175-K

Mounting block and screws

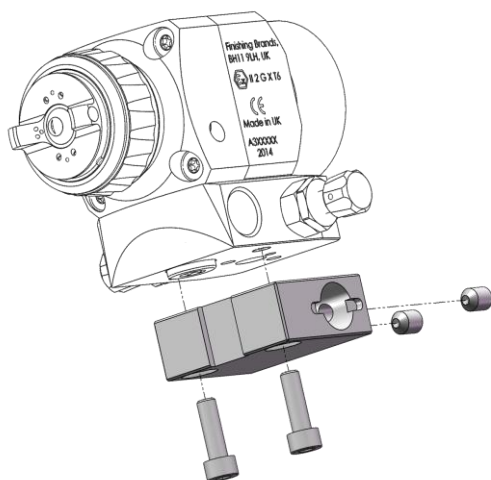





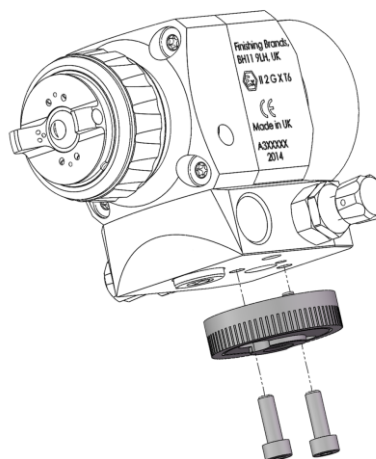



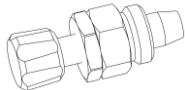

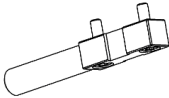

SPA-176-K

Index adjustment and screws



ACCESSORIES

PART No.	DESCRIPTION	
SPA-414-K	Control Valve	
SPA-423-K	Atomisation & fan low profile control valves, replaces items (33) see exploded view.	
SPA-173-K	Horizontal mounting bar and screws.	
SPA-174-K	Vertical mounting bar and screws.	
SPA-175-K	Mounting block and screws.	
SPA-176-K	Index adjustment and screws.	
SPA-115 SPA-116	1/4" NPT-NPS Elbow 275 Bar MWP. 1/4" NPT-BSP	
54-3655 54-1835	Housing & filter Filter element Filter 1/4" NPS M-F 100 Micron 400 Bar.	
H-5811 H-5813 H-5813-10	1m 7.5m 10m Airless hose 4.7mm bore 1/4" NPS F, 350 Bar MWP.	
H-5818 H-5819	7.5m 10m Airless hose 6.4mm bore 1/4" NPS F, 325 Bar MWP.	
4900-5-1-K3	Cleaning Brush (KIT OF 3)	
DSG-4003	Tip Cleaners (KIT OF 12)	
KK-4584	Gun Cleaning Kit	

DIMENSIONS

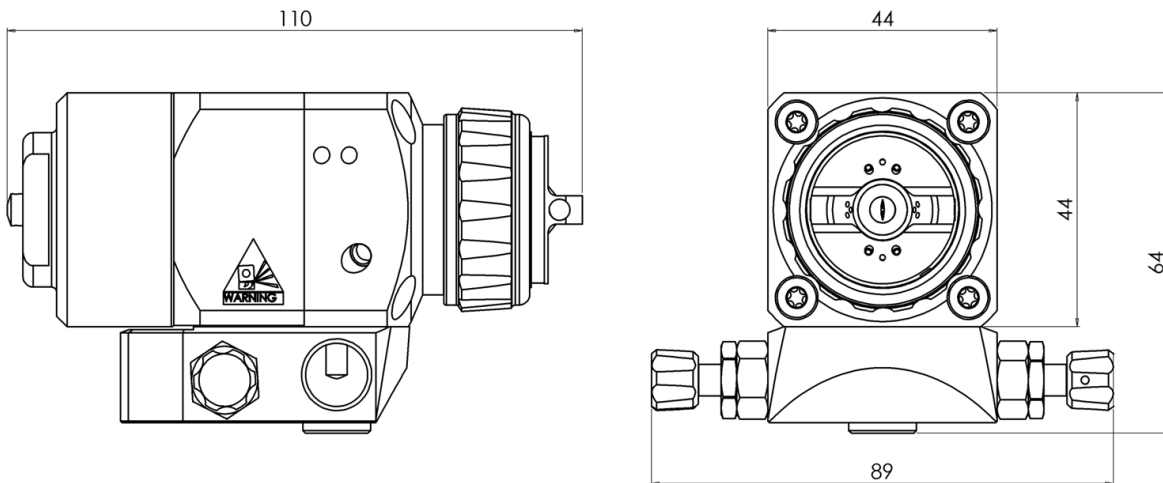

DISTRIBUTED BY COATING EQUIPMENT TECHNOLOGY, INC

NOTES

NOTES

WARRANTY POLICY

Binks products are covered by Finishing Brands one year materials and workmanship limited warranty. The use of any parts or accessories, from a source other than Finishing Brands, will void all warranties. For specific warranty information please contact the closest Finishing Brands location listed below.

Finishing Brands reserves the right to modify equipment specifications without prior notice. DeVilbiss, Ransburg, BGK, and Binks are registered trademarks of Carlisle Fluid Technologies, dba Finishing Brands.

© 2015 Carlisle Fluid Technologies, dba Finishing Brands.

All rights reserved.



Binks is part of Finishing Brands, a global leader in innovative spray finishing technologies. For technical assistance or to locate an authorised distributor, contact one of our international sales and customer support locations below.

USA/Canada

www.binks.com
info@finishingbrands.com
Toll Free Tel: 1-800-992-4657
Toll Free Fax: 1-888-246-5732

Mexico

www.finishingbrands.com.mx
sales@finishingbrands.com.mx
Tel: 011 52 55 5321 2300
Fax: 011 52 55 5310 4790

Brazil

www.devilbiss.com.br
sales@devilbiss.com.br
Tel: +55 11 5641 2776
Fax: +55 11 5641 1256

United Kingdom

www.finishingbrands.eu
info@finishingbrands.eu
Tel: +44 (0)1202 571 111
Fax: +44 (0)1202 573 488

France

www.finishingbrands.eu
info@finishingbrands.eu
Tel: +33(0)475 75 27 00
Fax: +33(0)475 75 27 59

Germany

www.finishingbrands.eu
info@finishingbrands.eu
Tel: +49 (0) 6074 403 1
Fax: +49 (0) 6074 403 281

China

www.finishingbrands.com.cn
mkt@finishingbrands.com.cn
Tel: +8621-3373 0108
Fax: +8621-3373 0308

Japan

www.ransburg.co.jp
binks-devilbiss@ransburg.co.jp
Tel: 081 45 785 6421
Fax: 081 45 785 6517

Australia

www.finishingbrands.com.au
sales@finishingbrands.com.au
Tel: +61 (0) 2 8525 7555
Fax: +61 (0) 2 8525 7575

